



<b>IMPORTANT FOR FUTURE REFERENCE</b>	
Please complete this information and retain this manual for the life of the equipment:	
Model #:	_____
Serial #:	_____
Date Purchased:	_____

## Installation & Operation Manual

# Gas Fired Full Jacket Steam Tilting Kettle FT-40GLS-SB



FT-40GLS-SB

### **WARNING**

Improper installation, adjustment, alteration, service or maintenance can cause property damage, injury or death. Read the installation, operating and maintenance instructions thoroughly before installing or servicing this equipment.

### **SOUTHBEND STEAM**

 **MIDDLEBY** A Middleby Company

1100 Old Honeycutt Road Fuquay-Varina, North Carolina 27526 USA

[www.southbendnc.com](http://www.southbendnc.com)



# SAFETY PRECAUTIONS

Before installing and operating this equipment, be sure everyone involved in its operation is fully trained and aware of precautions. Accidents and problems can be caused by failure to follow fundamental rules and precautions.

The following symbols, found throughout this manual, alert you to potentially dangerous conditions to the operator, service personnel, or to the equipment.



This symbol warns of immediate hazards that will result in severe injury or death.



This symbol refers to a potential hazard or unsafe practice that could result in injury or death.



This symbol refers to a potential hazard or unsafe practice that could result in injury, product damage, or property damage.



This symbol refers to information that needs special attention or must be fully understood, even though not dangerous.

## IMPORTANT NOTES FOR INSTALLATION AND OPERATION

### WARNING

This is the safety alert symbol. It is used to alert you to potential personal injury hazards. Obey all safety messages that follow this symbol to avoid possible injury or death.

### WARNING

FOR YOUR SAFETY:

Do not store or use gasoline or other flammable vapors or liquids in the vicinity of this or any other appliance.

### WARNING

Improper installation, operation, adjustment, alteration, service or maintenance can cause property damage, injury or death. Read the installation, operating and maintenance instructions thoroughly before installing, operating or servicing this equipment.

### NOTICE

This product is intended for commercial use only. NOT FOR HOUSEHOLD USE.

### NOTICE

This manual should be retained for future reference.

### IMPORTANT

**PURCHASER:** Instructions to be followed in the event that the operator of this appliance smells gas must be posted in a prominent location. This information shall be obtained by consulting the local gas supplier.

Do not obstruct the flow of combustion and ventilation air.

Keep the appliance area free and clear from combustibles.

Adequate clearances must be maintained for servicing and proper operation.

RETAIN THIS MANUAL FOR FUTURE REFERENCE.



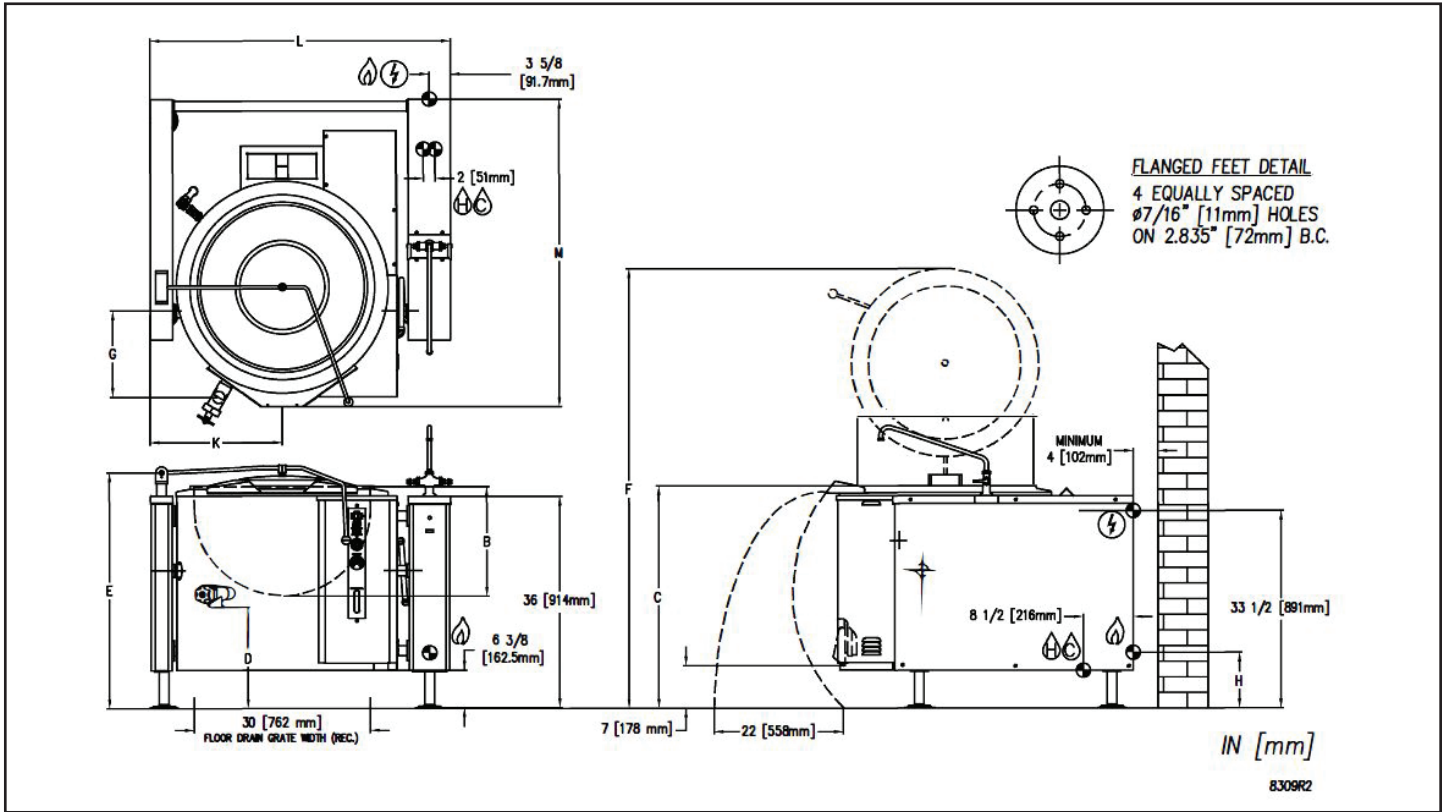

## Table of Contents

Important Notes For Installation and Operation .....	2
Service Connections .....	4
Installation .....	5
Operation .....	8
Cleaning.....	11
Maintenance .....	14
Troubleshooting .....	17
Appendix A, Material Safety Data Sheet .....	18

# SERVICE CONNECTIONS



## SERVICE CONNECTIONS

-  – GAS CONNECTION: Supply Gas through 3/4" pipe. A gas shut off valve must be installed in supply piping convenient and adjacent to appliance.
-  – ELECTRICAL CONNECTION : Unless otherwise specified, field wire electrical connection to be 120 volts, 60 Hz, 1 phase with grounding wire. Unit furnished with 6' cord and 3 prong plug. Total maximum amps 4.0.
-  – COLD WATER: 3/8" (10 mm) tubing to faucet (optional)
-  – HOT WATER: 3/8" (10 mm) tubing to faucet (optional)

## GAS CHARACTERISTICS

MODEL	GAS SUPPLY		
	BTU/HR.	KW/HR.	SUPPLY PIPE PRESSURE (W.C.)
FT-40GLS-SB	125,000	36.63	Natural 6"-14" (152-356 mm)
			Propane 11"-14" (279-356 mm)

## COMPARTMENT PAN CAPACITY AND SPECIFICATIONS

MODEL	PAN CAPACITY		SHIPPING WEIGHT	MINIMUM CLEARANCE	
FT-40GLS-SB	40 Gallon	152 Liter	1250 lbs. [567kg]	Sides	0" [0 mm]
				Back	4" [102 mm]

## DISCLAIMER

**Terry System Cartridge Changes / Installation** – “2-3 gallons of water MUST be purged at each cartridge change or new installation prior to water supply being fed to the steamer. Failure to do so can result in component damage within the steamer which is not covered under warranty. For additional guidance on proper installation, refer to install documentation provided with each Terry System and Replacement Cartridge Set.”

As continued product improvement is a policy of Southbend Steam, specifications are subject to change without notice.

# INSTALLATION

## UNPACKING

### IMMEDIATELY INSPECT FOR SHIPPING DAMAGE

Immediately after unpacking, check for possible shipping damage. If the tilting braising pan is found to be damaged, save the packaging material and contact the carrier within 15 days of delivery.

Before installing, verify that the electrical service agrees with the specifications on the rating plate located on the left side panel as you face the front of the braising pan. If the supply and equipment requirements do not agree, contact your dealer or Crown Food Service Equipment Ltd.

Information on the construction and installation of ventilating hoods may be obtained from the standard for “Vapor Removal from Cooking Equipment”, NFPA No. 96 (latest edition), available from the National Fire Protection Association, Batterymarch Park, Quincy, MA, USA, 02269.

## INSTALLATION INSTRUCTIONS

1. Uncrate carefully. Report any hidden freight damage to the freight company immediately.
2. The pressure relief valve is located at the right rear of the unit. This area should be kept clear and should not be in an area where operators will normally stand. The elbow on the relief valve should be turned toward the floor. A maximum 3 foot, 3/4” diameter pipe may be used to extend to the floor, but must not be piped directly to a drain. It must vent to the atmosphere.
3. Set the unit in place. Be certain to maintain minimum clearances as stated above.
4. To level the unit use a spirit level in all directions on the top of the kettle (lid up). Adjust the bottom foot on each leg to overcome an uneven floor.
5. Mark hole locations on floor through anchoring holes provided in flanged adjustable feet.
6. Remove appliance and drill holes in locations marked on floor and insert proper anchoring devices.
7. Set unit back in position and re-level left to right and front to back.
8. Bolt and anchor appliances securely to the floor.
9. Seal bolts and flanged feet with silastic or equivalent compound.
10. Appliance location must allow air supply to unit and obstruction free clearance for air opening into the combustion chamber.
11. Make service connections as indicated.
12. Check the pressure gauge on the front panel before operating. If the pressure gauge does not indicate green vacuum zone (below 0 psi), see “Re-establishing Vacuum” section under SERVICE, after completing installation instructions.

## GAS CONNECTION

The serial plate on the lower right side of the unit indicates the type of gas your unit is equipped to burn. Do NOT connect to any other gas type.

A 3/4” NPT line is provided at the rear for the connection. Each unit is equipped with an internal pressure regulator which is set for 3.5” W.C. manifold pressure for natural gas and 4.0” W.C. for propane gas. Use 1/8” pipe tap on the downstream side of the combination valve for checking pressure.

An adequate gas supply is imperative. Undersized or low pressure lines will restrict the volume of gas required for satisfactory performance. A steady pressure, minimum 6” W.C. for natural gas and minimum 11” W.C. for propane gas, is recommended. With all units operating simultaneously, the manifold pressure on all units should not show any appreciable drop. Fluctuations of more than 25% on natural gas, and 10% on propane gas, will create pilot problems and affect burner operating characteristics. Contact your gas company for correct supply line sizes.

Purge the supply line to clean out any dust, dirt, or other foreign matter before connecting the line to the unit. It is recommended that an individual manual shut off valve be installed in the gas supply line to the unit. Use pipe joint compound which is suitable for use with LP gas on all threaded connections. Test pipe connections thoroughly for gas leaks.

 **WARNING**

All connections must be checked for leaks, after the unit has been put in operation. Use soapy water only for testing on all gases. Never use an open flame to check for gas leaks.

**NOTICE**

If applicable, the vent line from the gas appliance pressure regulator shall be installed to the outdoors in accordance with local codes or, in the absence of local codes, with the National Fuel Gas Code, ANSI Z223.1/ NFPA 54, or the Natural Gas and Propane Installation Code CSA B149.1, as applicable.

**NOTICE**

If this equipment is being installed at over 2,000 feet altitude and was not so specified on order, contact service department. Failure to install with proper orifice sizing may void the warranty.

## WATER CONNECTION

On units equipped with an optional faucet, connect a 3/8" water line to the valve. Faucets with dual (hot and cold) valves must have the hot water line connected to side with the hot water valve (red) and cold water line to the cold water valve (blue). Plastic or rubber hose is not recommended, as it may melt against the hot kettle side.

## ELECTRICAL CONNECTION

 **WARNING**

Do not connect the kettle to the electrical supply until after the gas connection has been made.

1. 120 VAC - 60 Hz - Single Phase

 **WARNING**

Do not connect the kettle to the electrical supply until after the gas connection has been made.

 **WARNING****ELECTRICAL GROUNDING INSTRUCTIONS**

This appliance is equipped with a three-prong (grounding) plug for your protection against shock hazard and should be plugged directly into a properly grounded three-prong receptacle. Do not cut or remove the grounding prong from this plug. (120V units only).

Units with this electrical rating are factory supplied with a three-wired cord and three-prong plug which fits any standard 120V, three-prong grounded receptacle. A separate 15 amp supply is needed for each unit.

## 2. 208/240 VAC - 60 Hz - Single and Three Phase

Units with this electrical rating are factory equipped with a transformer. To connect supply wires, remove cover from right console. Route supply wires and ground wire through the hole in the console with a strain relief fitting. Connect wires to the terminal block in the rear of the right console. Connect ground wire to lug. Replace cover. Three-phase units are wired as above, using only two supply wires. The third supply wire is not connected and must be properly terminated.

## 3. 220 VAC - 50 Hz - Single Phase

Units equipped with this voltage ratings should be wired exactly as in Step 2 above.

# PERFORMANCE CHECK

The following items should be checked before or within the first 30 days of operation by a qualified service technician.

1. Verify correct gas type against rating plate on unit.
2. Verify correct voltage, cycle and phase against rating plate on unit.
3. Gas pressure.
4. Internal gas connections.
5. Internal electrical connections.
6. Burners - adjustment and ignition.
7. Thermostat - cycle for operation check.
8. Gas supply valve - check for operation.
9. Check hinge and lid assembly.
10. Draw-off valve - check operation.
11. Advise user on cleaning procedure.

# OPERATION

## NOTICE

Contact the factory, the factory representative or a local service company to perform maintenance and repairs should the appliance malfunction.

## CAUTION

If you smell gas during the lighting procedure, immediately shut off the gas supply until the leak has been corrected.

## WARNING

In the event of main burner ignition failure, a 5 minute purge period must be observed prior to re-establishing ignition source.

## WARNING

In the event you smell gas, shut down equipment at the main shut off valve and contact the local gas company or gas supplier for service.

## GAS CONTROL INSTRUCTIONS

The unit does not require “lighting” the pilot with a match.

## LIGHTING THE UNIT

## NOTICE

Unit is shipped with gas combination valve turned “on”.

1. Open manual gas shut
2. Set thermostat to OFF, and kettle in fully upright position, turn power switch ON.
3. Set thermostat to maximum, initiating a 30 second pre-purge. Red “COOKING” pilot will come on, and after 30 seconds, the green “IGNITION” pilot will come on, lighting the main burners.

If after 36 seconds the burner fails to ignite or the “ignition light goes out, the system goes into Safety Lockout. De-energize the system by setting the thermostat to “OFF” for five minutes and try again.

4. Set the thermostat to desired temperature setting. When temperature setting has been reached, the “IGNITION” pilot will go off, turning off the burner. The unit will then cycle on and off to maintain set temperature.

## NOTICE

When the kettle is tilted a safety switch will automatically turn off gas supply. The kettle will not operate once it has been tilted.

## DAILY SHUTDOWN

1. Turn power switch "OFF."
2. Turn thermostat "OFF."

## COMPLETE SHUTDOWN

1. Turn power switch "OFF."
2. Turn thermostat "OFF".
3. Turn power supply to unit "OFF".
4. Remove front access panel on left side and turn dial on combination valve to "OFF".
5. Close manual gas shut off valve.

## FRONT PANEL CONTROLS

**POWER SWITCH (ON/OFF)** ..... This switch turns the main power to the unit on and off. It must be turned on to heat the kettle. It should be turned off when the kettle will not be in use for long periods.

**IGNITION LIGHT (GREEN)**..... This light is on whenever the main burner gas is on.

**COOKING LIGHT (RED)**..... This light is on when the thermostat is calling for heat.

**LOW WATER LIGHT (AMBER)** ..... All kettles are supplied with sufficient distilled water in pressurized jacket. If at any time the water level falls below that required for proper operation, the kettle will not heat and this light will come on. See "Adding Water" in Service section.

**THERMOSTAT** ..... The thermostat selects the desired internal kettle operating temperature (jacket temperature). The thermostat must be set at a desired setting in order for the burner to ignite. Temperature ranges from roughly 165 °F to 274 °F (74 °C to 135 °C).

**PRESSURE GAUGE** ..... The pressure gauge indicates the internal operating pressure of the kettle. When cold, the gauge should point to the green vacuum zone. If it does not, refer to "Re-establishing Vacuum" section. Under normal operation with the kettle empty (thermostat set at 10 or 274 °F) the pressure should reach 30 psi. When loaded the pressure may be considerably less.

**SIGHT GLASS** ..... The sight glass indicates the minimum and maximum water level within the kettle. If water level falls below minimum level more distilled water should be added. See "Adding Water" in Service section.

**PRESSURE RELIEF VALVE** ..... The pressure relief valve is a safety device which prevents the internal kettle pressure from exceeding 50 psi. It should never be tampered with.

## DAILY OPERATION

Daily operation should consist of turning on the power switch and setting thermostat for the desired temperature.

It is recommended the kettle be preheated prior to use. Milk or egg based products should be placed in the kettle before heating however, to prevent sticking. The kettle is preheated when the cooking light goes off the first time.

At the end of the day, or if the kettle will not be used for some time, shut the unit down by turning the power switch to "OFF".

Clean as required or on a daily basis. See "CLEANING" section.

## END USER TIPS

For easier cleaning add cold water to the kettle immediately after removing contents.

When preparing foods containing vinegar or tomatoes, or those which have a high salt content, clean the kettle immediately after using to prevent pitting.

Do not use salt to clean the kettle. This will scratch the surface.

If using salt water to cook shellfish, be sure to rinse and wash the kettle thoroughly after use.

Bring milk and egg products slowly up to temperature in a cold kettle to prevent product from adhering to the sides. When preparing milk-based products do not preheat the kettle.

When planning actual cooking capacity, allow room at top for stirring without spilling.

When preparing puddings from a mix, place the powder in a cold kettle, add a small amount of liquid, and stir to form a thin paste. Turn on the kettle and add the remainder of the liquid. Continue as per recipe instructions.

When browning meat, bring the kettle up to temperature before adding. This will seal the juices in the meat.

## GAS SAVING TIPS

Use these reminders to help develop energy-saving procedures and habits. Using less natural or propane gas saves energy as well as money.

1. Turn off when not in use.
2. Limit preheat times.
3. Use lid when possible.
4. Maintain equipment.

# CLEANING

## CLEANING INSTRUCTIONS

 **WARNING**

Disconnect the power supply to the appliance before cleaning or servicing.

 **WARNING**

Never spray water into electric controls or components!

 **CAUTION**

The equipment and its parts are hot. Use care when operating, cleaning and servicing.

 **CAUTION**

Do not use cleaning agents that are corrosive.

Your kettle should be cleaned immediately after each use or when cooking a different product. Before cleaning, check that the kettle has cooled enough to touch it.

1. Rinse the inside of the kettle thoroughly and drain to remove any food particles.
2. Using a nylon brush, clean the kettle with a mild detergent and water. Never use steel wool or scouring powder as it will scratch stainless steel. Plain steel wool can leave small pieces of steel which can rust.
3. Rinse the inside of the kettle thoroughly with clean water. Drain the kettle by tilting or the tangent draw-off valve, depending on model, to allow the detergent and water solution to drain.
4. Wipe the exterior of the kettle with a clean, damp cloth.

 **WARNING**

If you are cleaning a valve that is assembled to a kettle, be sure the kettle is completely empty of any product.

## DRAW-OFF VALVE CLEANING

1. If equipped with a tangent draw-off valve, turn the large hex nut on the draw-off valve counterclockwise until it is completely disengaged from the threads. Grasp the valve knob and slowly pull out the valve stem and disk. Do not allow the disk to come in contact with hard surfaces as it can be damaged and cause valve leakage. Wash the valve stem, disk and handle. Insert a nylon brush, wet with detergent and water, into the valve body and tangent draw-off tube. Brush vigorously.
2. Replace the valve stem assembly and turn the hex nut until snug. Rinse the kettle with clean warm water.
3. Leave the draw-off valve open when the kettle is not in use.

## DAIRY DRAW-OFF VALVE CLEANING

1. Remove the plug by first removing the handle, then turn the plug to line up with the pin and pull with both hands. It is important to use both hands because the plug is heavy.
2. Put the plug in a plastic pail that contains a mild soap solution. A plastic pail works best, as it reduces the possibility of nicking or scratching the plug. If the plug gets scratched it may not seal correctly and could leak.
3. Use a soft cloth or soft brush and clean all surfaces.
4. Using both hands remove the valve from the soap and rinse well in another plastic pail that contains fresh water.
5. Wash out the kettle as normal.
6. Once the kettle is washed out, return the plug into the body. Be sure the plug is inserted into the notch and turned. Ensure the plug is tight and secure before letting go of it.

If you are cleaning a body and plug assembly, remove the plug and follow the above procedures. When finished with the plug, follow the same instructions for washing the body. Always use both hands when handling the plugs. Reassemble the plug into the body and use as normal.

### NOTICE

Draw-off valve has a vulcanized rubber coated stem for better sealing. Do not over tighten. This may cause the rubber to pull away from stem and permanently damage it. This is not covered under warranty.

## WHAT TO DO IF SURFACE RUST APPEARS

Metal utensils should never be used as they will scratch the surface of the equipment and rust may begin to form. To remove surface accumulation of rust from the inadvertent use of such utensils, the following procedure may be used.

### CAUTION

Improper use of this procedure may damage your appliance!

1. Use undiluted white vinegar with a non-abrasive scouring pad (plastic) or cloth on the affected area to remove the rust stain. The appliance should not be heated and remain at room temperature during the entire cleaning process.
2. If the stain resists removal, additional exposure time with vinegar may be required, to a maximum of one hour.
3. Thoroughly wash all of the vinegar away with fresh clear water. Dry the surface completely and allow one hour before using the appliance to cook.

Following daily and period maintenance procedures will prolong the life for your equipment. Climatic conditions - salt air - may require more thorough and frequent cleaning or the life of the equipment could be adversely affected.

## STAINLESS STEEL

To remove normal dirt, grease or product residue from stainless steel, use ordinary soap and water (with or without detergent) applied with a sponge or cloth. Dry thoroughly with a clean cloth. Never use vinegar or any other corrosive cleaner.

To remove grease and food splatters or condensed vapours that have baked on the equipment, apply cleanser to a damp cloth or sponge and rub cleanser on the metal in the direction of the polishing lines. Rubbing cleanser as gently as possible in the direction of the polished lines will not mar the finish of the stainless steel. **NEVER RUB WITH A CIRCULAR MOTION.**

Soil and burn deposits which do not respond to the above procedure can usually be removed by rubbing the surface with **SCOTCH-BRITE™** scouring pads or **STAINLESS** scouring pads. **DO NOT USE ORDINARY STEEL WOOL** as any particles left on the surface will rust and further spoil the appearance of the finish. **NEVER USE A WIRE BRUSH, STEEL SCOURING PADS (EXCEPT STAINLESS), SCRAPER, FILE OR OTHER STEEL TOOLS.** Surfaces which are marred collect dirt more rapidly and become more difficult to clean. Marring also increases the possibility of corrosive attack. Refinishing may then be required.

**TO REMOVE HEAT TINT:** Darkened areas sometimes appear on stainless steel surfaces where the area has been subjected to excessive heat. These darkened areas are caused by thickening of the protective surface of the stainless steel and is not harmful. Heat tint can normally be removed by the foregoing, but tint which does not respond to this procedure calls for a vigorous scouring in the direction of the polish lines using **SCOTCH-BRITE™** scouring pads or a **STAINLESS** scouring pad in combination with a powdered cleanser. Heat tint action may be lessened by not applying or by reducing heat to equipment during slack periods.

All food contact surfaces must be thoroughly drained and flushed prior to cooking in the kettle.

**CONTROL PANEL:** The textured control panel should be cleaned with warm water and mild soap. Never use an abrasive cloth or steel wool. Never use cleaning solvents with a hydrocarbon base.

# MAINTENANCE

## NOTICE

Contact the factory, the factory representative or a local service company to perform maintenance and repairs.

## WARNING

Disconnect the power supply to the appliance before cleaning or servicing.

## DAILY

1. Wash exposed cleanable areas.

## MONTHLY

1. Blower wheel inlet and motor air vent should be cleansed if an accumulation of dust or lint is obvious.

## TWICE A YEAR (MINIMUM)

1. Have an authorized service person clean and adjust the unit for maximum performance.
2. The unit venting system should be examined and cleaned.

## SERVICE

## GENERAL

When any difficulty arises always check that the unit has been connected to the gas supply type and voltage for which it was supplied. This can be done by examining the serial plate on the lower right side of the unit. It will list the gas type and voltage for which the unit was manufactured.

Wiring diagrams for the unit are located in a small envelope affixed to the side panel of left hand console.

UNIT	TOTAL INPUT	ORIFICE SIZE	
		Natural	Propane
GLT-40FL	125,000 BTU/Hour	DMS # 4 (.209")	DMS # 20 (.161")

## MANIFOLD PRESSURE

Natural Gas - 3.5 inches W.C.      LP Gas - 4 inches W.C.

## Adjustments

## WARNING

Adjustments and service work may be performed only by a qualified technician who is experienced in, and knowledgeable with, the operation of commercial gas cooking equipment. To assure your confidence, contact your authorized service agency for reliable service, dependable advice or other assistance, and for genuine factory parts.

## THERMOSTAT

The thermostat adjustment should not be changed. Check the following before changing the thermostat.

1. With kettle cold, the pressure on the pressure gauge should read in the green vacuum zone (25 to 30 inches Hg vacuum). If not, see 'Re-establishing Vacuum" section.
2. The pressure switch may be set too high or too low and causing the out of adjustment condition. A voltmeter should be used by a properly trained serviceman to determine if the pressure switch or thermostat is actually cycling the burners. If the pressure switch is found to be cycling the burners, see "Pressure Switch" section.

After verifying that the pressure switch is set and operating properly, to set thermostat, adjust the trim-pot on the control inside the kettle. It is located next to terminal 2 and is not sealed. Turning the pot clockwise will lower the temperature setting, counterclockwise increases the temperature. At maximum setting, the thermostat should cycle off at a gauge pressure reading of 30 psi. Turn set screw clockwise to decrease pressure and counterclockwise to increase pressure.

## PRESSURE SWITCH

The pressure switch should not be adjusted until it is determined to be the cause of an operating pressure difficulty. See "Thermostat" section to determine if the source of difficulty is the pressure switch or thermostat.

The major difficulties caused by pressure switch mis-adjustment are:

1. Pressure relief valve opening, pressure rises above 45 psi.
2. Pressure in kettle is less than 30 psi and burner is being shut down by pressure switch (not thermostat).

The pressure switch is preset for proper operation from the factory. It is adjusted to the maximum pressure which will prevent the pressure relief valve from opening. During preheat to the maximum thermostat setting (274 °F), from either a cold condition or a lower temperature setting, the temperature may overshoot the thermostat setting and be shut down by the pressure switch. This is normal, however, after the kettle has cycled several times (empty) the thermostat will begin cycling the unit.

## ADJUST PRESSURE SWITCH

1. To obtain access to the pressure switch, the front panel must be removed. Remove the screws on bottom of the panel. Be sure to support the panel to avoid excessive strain on the wiring.
2. To increase the pressure switch setting, turn the white ribbed knob clockwise; to decrease, turn it counterclockwise. Use the centre of the black ring as an indicator.
3. With the kettle empty and completely cold, turn kettle on and set thermostat to maximum setting (274 °F).
4. The pressure in kettle (read pressure gauge on front panel) should reach a maximum of 30 psi and burners should shut down. Kettle pressure may rise 3 or 4 psi even after burners shut down.
5. Kettle should be shut down by the pressure switch at maximum of 45 psi. The pressure relief valve should not open. Pressure switch setting is satisfactory.
6. If the safety relief valve opens, reduce setting on pressure switch, cool kettle completely by running cold water through it and repeat steps 3 - 6.
7. If pressure switch shuts down the kettle below 30 psi increase setting of pressure switch, cool kettle completely by running cold water through it and repeat steps 3 - 7.
8. Allow the kettle to cycle several times to verify the correct pressure setting.
9. Replace the front panel when adjustment is complete.

## ADDING WATER (LOW WATER LIGHT COMES ON.)

It may be necessary to replenish water in the jacket when the low water indicator comes on. Do so as follows:

1. Unit should be completely cold and off.
2. Lift handle of pressure relief valve to release vacuum in kettle. (Relief valve is at right rear of kettle.
3. Remove air vent nut on the tee located next to the relief valve.
4. Using pure distilled water only, pour the water into the opening (a funnel will be helpful). Water will enter the kettle slowly, as air must escape through the same hole. Water should be added until water level at the sight glass is half way between the minimum and maximum levels.
5. When sufficient water has been added, replace and tighten the nut. Be sure to seal threads with a pipe joint compound suitable for steam at 50 psi.
6. Vacuum must be re-established (See Re-establishing Vacuum).

### FOR REFERENCE

The amount of distilled water to be added when low level pilot is illuminated is 338 fl. oz. (10 L). Total amount of liquid from empty is 1,488 fl. oz. (44 L).

## RE-ESTABLISHING VACUUM

Periodically check pressure gauge when kettle is cold. Reading should be in green vacuum zone (below 0 psi). Otherwise air is present and proper heating will not occur. Use the following procedure to remove air and re-establish vacuum:

With the kettle empty, turn the thermostat knob to the highest temperature. When the temperature pilot light goes off, open air vent nut one (1) full turn for 45 seconds and then close and tighten the nut. This should remove the air and any loss in performance should return.

Should the kettle fail to maintain a vacuum after repeated attempts to establish vacuum, further checks should be made to see if the pressure relief valve is leaking or if there are any leaks in the pressure relief valve piping, copper lines going to the pressure switch, pressure gauge or thermostat fitting.

## SAFETY VALVE MAINTENANCE AND TESTING

### CAUTION

Under normal operating conditions a “try lever test” should be performed every two months. Under severe service conditions, or if corrosion and/or deposits are noticed within the valve body, testing must be performed more often. A “try lever test” should also be performed at the end of any non-service period.

### CAUTION

Hot, high pressure fluid may be discharged from body drain and vent during “try lever” test. Care must be taken to avoid any bodily contact.

### CAUTION

High sound levels may be experienced during “try lever” test. Wear proper safety equipment and exercise extreme care! Test at, or near, half of the operating pressure by holding the test lever fully open for at least two seconds to flush the valve seat free of sediment and debris. Then release lever and permit the valve to snap shut.

If lift lever does not activate, or there is no evidence of discharge, turn off equipment immediately and contact a licensed contractor or qualified service personnel.

# TROUBLESHOOTING

PROBLEM	LOOK FOR
Motor will not run.	<ul style="list-style-type: none"> <li>No current. Check that power is being supplied to the unit.</li> <li>Defective thermostat or pressure switch.</li> <li>Defective motor.</li> <li>Motor overload out.</li> <li>Blown fuse.</li> </ul>
Motor runs, no spark.	<ul style="list-style-type: none"> <li>Defective transformer.</li> <li>Defective ignition module.</li> <li>Blown fuse on ignition module.</li> <li>Defective spark electrode (cracked insulator).</li> <li>Defective ignition cable.</li> <li>Defective centrifugal switch on motor.</li> </ul>
Motor runs, spark present, no gas ignition.	<ul style="list-style-type: none"> <li>Manual main valve off.</li> <li>Mislocated spark or ground rods.</li> <li>Defective valve.</li> <li>Defective ignition module.</li> <li>Burner rate set too high. Ensure that manifold pressure is set per rating plate and that correct orifice size installed (See table page 14).</li> <li>Burner getting too much air. Reduce air shutter opening (not below 1.0).</li> </ul>
Low water light comes on.	<ul style="list-style-type: none"> <li>Add water - See previous section ADJUSTMENTS.</li> </ul>
Relief valve opens.	<ul style="list-style-type: none"> <li>Pressure switch set too high.</li> <li>Pressure gauge is not accurate.</li> <li>Relief valve is faulty.</li> </ul>
Flame burns only about 6 seconds and shuts off.	<ul style="list-style-type: none"> <li>Flame rod or flame ground mislocated.</li> <li>Defective flame rod wire.</li> <li>Defective ignition module.</li> <li>Burner rate set too high. Ensure that manifold pressure is set per rating plate and that correct orifice size installed. (See table page 14).</li> <li>Burner getting too much air. Reduce air shutter opening (not below 1.0).</li> </ul>
Short flame.	<ul style="list-style-type: none"> <li>Wrong size orifice. (See table on page 14).</li> <li>Low gas pressure.</li> <li>Air shutter adjustment.</li> <li>Main manual valve partially closed.</li> </ul>
Long hazy flame.	<ul style="list-style-type: none"> <li>Wrong size orifice.</li> <li>High gas pressure.</li> <li>Dirty blower wheel or intake.</li> <li>Air shutter adjustments.</li> </ul>
Gas fails to shut off.	<ul style="list-style-type: none"> <li>Dirt on valve seat.</li> <li>Defective main valve.</li> </ul>

## NOTICE

Loose, broken or grounded wiring may cause many of the symptoms listed. Check all wiring and make sure it is intact.



## SAFETY DATA SHEET

### DOW CHEMICAL CANADA ULC

**Product name:** DOWFROST™ HD Heat Transfer Fluid, Dyed

**Issue Date:** 01/19/2017

**Print Date:** 01/23/2017

DOW CHEMICAL CANADA ULC encourages and expects you to read and understand the entire (M)SDS, as there is important information throughout the document. We expect you to follow the precautions identified in this document unless your use conditions would necessitate other appropriate methods or actions.

## 1. IDENTIFICATION

**Product name:** DOWFROST™ HD Heat Transfer Fluid, Dyed

### Recommended use of the chemical and restrictions on use

**Identified uses:** Intended as a heat transfer fluid for closed-loop systems. We recommend that you use this product in a manner consistent with the listed use. If your intended use is not consistent with the stated use, please contact your sales or technical service representative.

### COMPANY IDENTIFICATION

DOW CHEMICAL CANADA ULC  
#2400, 215 - 2ND STREET S.W.  
CALGARY AB T2P 1M4  
CANADA

**Customer Information Number:**

800-258-2436  
SDSQuestion@dow.com

### EMERGENCY TELEPHONE NUMBER

**24-Hour Emergency Contact:** 1-888-226-8832

**Local Emergency Contact:** 613-996-6666

## 2. HAZARDS IDENTIFICATION

### Hazard classification

This product is not hazardous under the criteria of the Hazardous Products Regulation (HPR) as implemented under the Workplace Hazardous Materials Information System (WHMIS 2015).

### Other hazards

No data available

## 3. COMPOSITION/INFORMATION ON INGREDIENTS

This product is a mixture.

Component	CASRN	Concentration
-----------	-------	---------------

---

Propylene glycol	57-55-6	> 93.0 %
Water	7732-18-5	< 5.0 %
Dipotassium hydrogen phosphate	7758-11-4	< 5.0 %

---

#### 4. FIRST AID MEASURES

---

##### Description of first aid measures

**General advice:** If potential for exposure exists refer to Section 8 for specific personal protective equipment.

**Inhalation:** Move person to fresh air; if effects occur, consult a physician.

**Skin contact:** Wash off with plenty of water.

**Eye contact:** Flush eyes thoroughly with water for several minutes. Remove contact lenses after the initial 1-2 minutes and continue flushing for several additional minutes. If effects occur, consult a physician, preferably an ophthalmologist.

**Ingestion:** No emergency medical treatment necessary.

**Most important symptoms and effects, both acute and delayed:** Aside from the information found under Description of first aid measures (above) and Indication of immediate medical attention and special treatment needed (below), any additional important symptoms and effects are described in Section 11: Toxicology Information.

##### Indication of any immediate medical attention and special treatment needed

**Notes to physician:** No specific antidote. Treatment of exposure should be directed at the control of symptoms and the clinical condition of the patient.

---

#### 5. FIREFIGHTING MEASURES

---

**Suitable extinguishing media:** Water fog or fine spray. Dry chemical fire extinguishers. Carbon dioxide fire extinguishers. Foam. Alcohol resistant foams (ATC type) are preferred. General purpose synthetic foams (including AFFF) or protein foams may function, but will be less effective.

**Unsuitable extinguishing media:** Do not use direct water stream. May spread fire.

##### Special hazards arising from the substance or mixture

**Hazardous combustion products:** During a fire, smoke may contain the original material in addition to combustion products of varying composition which may be toxic and/or irritating. Combustion products may include and are not limited to: Carbon monoxide. Carbon dioxide.

**Unusual Fire and Explosion Hazards:** Container may rupture from gas generation in a fire situation. Violent steam generation or eruption may occur upon application of direct water stream to hot liquids.

**Advice for firefighters**

**Fire Fighting Procedures:** Keep people away. Isolate fire and deny unnecessary entry. Use water spray to cool fire exposed containers and fire affected zone until fire is out and danger of reignition has passed. Fight fire from protected location or safe distance. Consider the use of unmanned hose holders or monitor nozzles. Immediately withdraw all personnel from the area in case of rising sound from venting safety device or discoloration of the container. Burning liquids may be extinguished by dilution with water. Do not use direct water stream. May spread fire. Move container from fire area if this is possible without hazard. Burning liquids may be moved by flushing with water to protect personnel and minimize property damage.

**Special protective equipment for firefighters:** Wear positive-pressure self-contained breathing apparatus (SCBA) and protective fire fighting clothing (includes fire fighting helmet, coat, trousers, boots, and gloves). If protective equipment is not available or not used, fight fire from a protected location or safe distance.

**6. ACCIDENTAL RELEASE MEASURES**

**Personal precautions, protective equipment and emergency procedures:** Keep unnecessary and unprotected personnel from entering the area. Use appropriate safety equipment. For additional information, refer to Section 8, Exposure Controls and Personal Protection.

**Environmental precautions:** Prevent from entering into soil, ditches, sewers, waterways and/or groundwater. See Section 12, Ecological Information.

**Methods and materials for containment and cleaning up:** Small spills: Absorb with materials such as: Cat litter. Sawdust. Vermiculite. Zorb-all®. Collect in suitable and properly labeled containers. Large spills: Dike area to contain spill. See Section 13, Disposal Considerations, for additional information.

**7. HANDLING AND STORAGE**

**Precautions for safe handling: Conditions for safe storage:** Do not store in: Galvanized steel. Opened or unlabeled containers. Store in the following material(s): Carbon steel. Stainless steel. Store in original unopened container. See Section 10 for more specific information. Additional storage and handling information on this product may be obtained by calling your sales or customer service contact.

**8. EXPOSURE CONTROLS/PERSONAL PROTECTION**

**Control parameters**

Exposure limits are listed below, if they exist.

Component	Regulation	Type of listing	Value/Notation
Propylene glycol	US WEEL	TWA	10 mg/m3
	CA ON OEL	TWAEV Total	155 mg/m3 50 ppm
	CA ON OEL	TWAEV	10 mg/m3
	CA ON OEL	TWA	155 mg/m3 50 ppm
	CA ON OEL	TWA	10 mg/m3
	CA ON OEL	TWA Vapour and aerosols	155 mg/m3 50 ppm
	CA ON OEL	TWA aerosol	10 mg/m3

Consult local authorities for recommended exposure limits.

### Exposure controls

**Engineering controls:** Use local exhaust ventilation, or other engineering controls to maintain airborne levels below exposure limit requirements or guidelines. If there are no applicable exposure limit requirements or guidelines, general ventilation should be sufficient for most operations. Local exhaust ventilation may be necessary for some operations.

### Individual protection measures

**Eye/face protection:** Use safety glasses (with side shields).

#### Skin protection

**Hand protection:** Use gloves chemically resistant to this material when prolonged or frequently repeated contact could occur. Examples of preferred glove barrier materials include: Butyl rubber. Natural rubber ("latex"). Neoprene. Nitrile/butadiene rubber ("nitrile" or "NBR"). Polyethylene. Ethyl vinyl alcohol laminate ("EVAL"). Polyvinyl alcohol ("PVA"). Polyvinyl chloride ("PVC" or "vinyl"). NOTICE: The selection of a specific glove for a particular application and duration of use in a workplace should also take into account all relevant workplace factors such as, but not limited to: Other chemicals which may be handled, physical requirements (cut/puncture protection, dexterity, thermal protection), potential body reactions to glove materials, as well as the instructions/specifications provided by the glove supplier.

**Other protection:** Wear clean, body-covering clothing.

**Respiratory protection:** Respiratory protection should be worn when there is a potential to exceed the exposure limit requirements or guidelines. If there are no applicable exposure limit requirements or guidelines, wear respiratory protection when adverse effects, such as respiratory irritation or discomfort have been experienced, or where indicated by your risk assessment process. In misty atmospheres, use an approved particulate respirator. The following should be effective types of air-purifying respirators: Organic vapor cartridge with a particulate pre-filter.

## 9. PHYSICAL AND CHEMICAL PROPERTIES

### Appearance

<b>Physical state</b>	Liquid.
<b>Color</b>	Yellow to green
<b>Odor</b>	Characteristic
<b>Odor Threshold</b>	No test data available
<b>pH</b>	9.5 50% <i>Literature</i>
<b>Melting point/range</b>	Not applicable to liquids
<b>Freezing point</b>	supercools
<b>Boiling point (760 mmHg)</b>	152 °C <i>Literature</i>
<b>Flash point</b>	<b>closed cup</b> 104 °C <i>Pensky-Martens Closed Cup ASTM D 93</i> Propylene glycol., (based on major component)
<b>Evaporation Rate (Butyl Acetate = 1)</b>	< 0.5 <i>Estimated.</i>
<b>Flammability (solid, gas)</b>	Not applicable to liquids
<b>Lower explosion limit</b>	2.6 % vol <i>Literature</i> Propylene glycol.
<b>Upper explosion limit</b>	12.5 % vol <i>Literature</i> Propylene glycol.

<b>Vapor Pressure</b>	2.2 mmHg <i>Literature</i>
<b>Relative Vapor Density (air = 1)</b>	>1.0 <i>Literature</i>
<b>Relative Density (water = 1)</b>	1.06 at 20 °C / 20 °C <i>Literature</i>
<b>Water solubility</b>	100 % <i>Literature</i>
<b>Partition coefficient: n-octanol/water</b>	No data available
<b>Auto-ignition temperature</b>	371 °C <i>Literature</i> Propylene glycol.
<b>Decomposition temperature</b>	No test data available
<b>Kinematic Viscosity</b>	43.4 cSt at 20 °C <i>Literature</i>
<b>Explosive properties</b>	No data available
<b>Oxidizing properties</b>	No data available
<b>Molecular weight</b>	No data available

NOTE: The physical data presented above are typical values and should not be construed as a specification.

---

## 10. STABILITY AND REACTIVITY

---

**Reactivity:** No data available

**Chemical stability:** Stable under recommended storage conditions. See Storage, Section 7. Hygroscopic

**Possibility of hazardous reactions:** Polymerization will not occur.

**Conditions to avoid:** Exposure to elevated temperatures can cause product to decompose. Generation of gas during decomposition can cause pressure in closed systems. Avoid direct sunlight or ultraviolet sources.

**Incompatible materials:** Avoid contact with: Strong acids. Strong bases. Strong oxidizers.

**Hazardous decomposition products:** Decomposition products depend upon temperature, air supply and the presence of other materials. Decomposition products can include and are not limited to: Aldehydes. Alcohols. Ethers. Organic acids.

---

## 11. TOXICOLOGICAL INFORMATION

---

*Toxicological information appears in this section when such data is available.*

### Acute toxicity

#### Acute oral toxicity

Very low toxicity if swallowed. Harmful effects not anticipated from swallowing small amounts.

For the major component(s): Propylene glycol.  
LD50, Rat, > 20,000 mg/kg

#### Acute dermal toxicity

Prolonged skin contact is unlikely to result in absorption of harmful amounts.

For the major component(s): Propylene glycol.  
LD50, Rabbit, > 20,000 mg/kg

**Acute inhalation toxicity**

At room temperature, exposure to vapor is minimal due to low volatility. Mist may cause irritation of upper respiratory tract (nose and throat).

For the major component(s):  
LC50, Rat, 4 Hour, vapour, 6.15 mg/l No deaths occurred following exposure to a saturated atmosphere.

**Skin corrosion/irritation**

Prolonged contact is essentially nonirritating to skin.  
Repeated contact may cause flaking and softening of skin.

**Serious eye damage/eye irritation**

May cause slight temporary eye irritation.  
Corneal injury is unlikely.

**Sensitization**

For the major component(s):  
Did not cause allergic skin reactions when tested in humans.

For respiratory sensitization:  
No relevant data found.

**Specific Target Organ Systemic Toxicity (Single Exposure)**

Evaluation of available data suggests that this material is not an STOT-SE toxicant.

**Specific Target Organ Systemic Toxicity (Repeated Exposure)**

In rare cases, repeated excessive exposure to propylene glycol may cause central nervous system effects.

**Carcinogenicity**

Similar formulations did not cause cancer in laboratory animals.

**Teratogenicity**

For the major component(s): Did not cause birth defects or any other fetal effects in laboratory animals.

**Reproductive toxicity**

For the major component(s): In animal studies, did not interfere with reproduction. In animal studies, did not interfere with fertility.

**Mutagenicity**

In vitro genetic toxicity studies were negative. For the major component(s): Animal genetic toxicity studies were negative.

**Aspiration Hazard**

Based on physical properties, not likely to be an aspiration hazard.

---

---

## 12. ECOLOGICAL INFORMATION

---

*Ecotoxicological information appears in this section when such data is available.*

### Toxicity

#### Propylene glycol

##### **Acute toxicity to fish**

Material is practically non-toxic to aquatic organisms on an acute basis (LC50/EC50/EL50/LL50 >100 mg/L in the most sensitive species tested).  
LC50, *Oncorhynchus mykiss* (rainbow trout), static test, 96 Hour, 40,613 mg/l, OECD Test Guideline 203

##### **Acute toxicity to aquatic invertebrates**

LC50, *Ceriodaphnia dubia* (water flea), static test, 48 Hour, 18,340 mg/l, OECD Test Guideline 202

##### **Acute toxicity to algae/aquatic plants**

ErC50, *Pseudokirchneriella subcapitata* (green algae), 96 Hour, Growth rate inhibition, 19,000 mg/l, OECD Test Guideline 201

##### **Toxicity to bacteria**

NOEC, *Pseudomonas putida*, 18 Hour, > 20,000 mg/l

##### **Chronic toxicity to aquatic invertebrates**

NOEC, *Ceriodaphnia dubia* (water flea), semi-static test, 7 d, number of offspring, 13,020 mg/l

#### Dipotassium hydrogen phosphate

##### **Acute toxicity to fish**

Material is practically non-toxic to aquatic organisms on an acute basis (LC50/EC50/EL50/LL50 >100 mg/L in the most sensitive species tested).  
LC50, *Leuciscus idus* (Golden orfe), static test, 48 Hour, > 900 mg/l, Method Not Specified.

### Persistence and degradability

#### Propylene glycol

**Biodegradability:** Material is readily biodegradable. Passes OECD test(s) for ready biodegradability. Biodegradation may occur under anaerobic conditions (in the absence of oxygen).

10-day Window: Pass

**Biodegradation:** 81 %

**Exposure time:** 28 d

**Method:** OECD Test Guideline 301F or Equivalent

10-day Window: Not applicable

**Biodegradation:** 96 %

**Exposure time:** 64 d

**Method:** OECD Test Guideline 306 or Equivalent

**Theoretical Oxygen Demand:** 1.68 mg/mg

**Chemical Oxygen Demand:** 1.53 mg/mg

**Biological oxygen demand (BOD)**

Incubation Time	BOD
5 d	69.000 %
10 d	70.000 %
20 d	86.000 %

**Photodegradation****Atmospheric half-life:** 10 Hour**Method:** Estimated.**Dipotassium hydrogen phosphate****Biodegradability:** Biodegradation is not applicable.**Bioaccumulative potential****Propylene glycol****Bioaccumulation:** Bioconcentration potential is low (BCF < 100 or Log Pow < 3).**Partition coefficient: n-octanol/water(log Pow):** -1.07 Measured**Bioconcentration factor (BCF):** 0.09 Estimated.**Dipotassium hydrogen phosphate****Bioaccumulation:** No bioconcentration is expected because of the relatively high water solubility.**Mobility in soil****Propylene glycol**

Given its very low Henry's constant, volatilization from natural bodies of water or moist soil is not expected to be an important fate process.

Potential for mobility in soil is very high (Koc between 0 and 50).

**Partition coefficient (Koc):** < 1 Estimated.**Dipotassium hydrogen phosphate**

No relevant data found.

---

**13. DISPOSAL CONSIDERATIONS**

---

**Disposal methods:** DO NOT DUMP INTO ANY SEWERS, ON THE GROUND, OR INTO ANY BODY OF WATER. All disposal practices must be in compliance with all Federal, State/Provincial and local laws and regulations. Regulations may vary in different locations. Waste characterizations and compliance with applicable laws are the responsibility solely of the waste generator. AS YOUR SUPPLIER, WE HAVE NO CONTROL OVER THE MANAGEMENT PRACTICES OR MANUFACTURING PROCESSES OF PARTIES HANDLING OR USING THIS MATERIAL. THE INFORMATION PRESENTED HERE PERTAINS ONLY TO THE PRODUCT AS SHIPPED IN ITS INTENDED CONDITION AS DESCRIBED IN MSDS SECTION: Composition Information. FOR UNUSED & UNCONTAMINATED PRODUCT, the preferred options include sending to a licensed, permitted: Recycler. Reclaimer. Incinerator or other thermal destruction device.

---



---

## 14. TRANSPORT INFORMATION

---

**TDG**

Not regulated for transport

**Classification for SEA transport (IMO-IMDG):**

**Transport in bulk  
according to Annex I or II  
of MARPOL 73/78 and the  
IBC or IGC Code**

Not regulated for transport  
Consult IMO regulations before transporting ocean bulk

**Classification for AIR transport (IATA/ICAO):**

Not regulated for transport

This information is not intended to convey all specific regulatory or operational requirements/information relating to this product. Transportation classifications may vary by container volume and may be influenced by regional or country variations in regulations. Additional transportation system information can be obtained through an authorized sales or customer service representative. It is the responsibility of the transporting organization to follow all applicable laws, regulations and rules relating to the transportation of the material.

---



---

## 15. REGULATORY INFORMATION

---

**Canadian Domestic Substances List (DSL)**

This product contains at least one substance which is not listed on the Canadian Domestic Substances List (DSL).

---



---

## 16. OTHER INFORMATION

---

**Hazard Rating System****NFPA**

Health	Fire	Reactivity
0	1	0

**Revision**

Identification Number: 101199333 / A208 / Issue Date: 01/19/2017 / Version: 7.0

Most recent revision(s) are noted by the bold, double bars in left-hand margin throughout this document.

**Legend**

CA ON OEL	Canada, Ontario OELs
-----------	----------------------

---

TWA	8-hr Time Weighted Average
TWAEV	time-weighted average exposure value
US WEEL	USA. Workplace Environmental Exposure Levels (WEEL)

**Information Source and References**

This SDS is prepared by Product Regulatory Services and Hazard Communications Groups from information supplied by internal references within our company.

DOW CHEMICAL CANADA ULC urges each customer or recipient of this (M)SDS to study it carefully and consult appropriate expertise, as necessary or appropriate, to become aware of and understand the data contained in this (M)SDS and any hazards associated with the product. The information herein is provided in good faith and believed to be accurate as of the effective date shown above. However, no warranty, express or implied, is given. Regulatory requirements are subject to change and may differ between various locations. It is the buyer's/user's responsibility to ensure that his activities comply with all federal, state, provincial or local laws. The information presented here pertains only to the product as shipped. Since conditions for use of the product are not under the control of the manufacturer, it is the buyer's/user's duty to determine the conditions necessary for the safe use of this product. Due to the proliferation of sources for information such as manufacturer-specific (M)SDSs, we are not and cannot be responsible for (M)SDSs obtained from any source other than ourselves. If you have obtained an (M)SDS from another source or if you are not sure that the (M)SDS you have is current, please contact us for the most current version.

# Gas Fired Full Jacket Steam Tilting Kettle FT-40GLS-SB



A product with the Southbend Steam name incorporates the best in durability and low maintenance. We all recognize, however, that replacement parts and occasional professional service may be necessary to extend the useful life of this appliance. When service is needed, contact a Southbend Steam Authorized Service Agency, or your dealer. To avoid confusion, always refer to the model number, serial number, and type of your appliance.



**SOUTHBEND STEAM**  
 **MIDDLEBY** A Middleby Company  
1100 Old Honeycutt Road Fuquay-Varina, North Carolina 27526 USA  
[www.southbendnc.com](http://www.southbendnc.com)